

Op-Lite



collection





1] Op-Lite II O Bench 2-person workstation
 2] AcuStixx - modular system of standalone partitions

Information library



B2B Platform



Order MARO products on our B2B platform!



Photobank



Download all the necessary materials from our base.



pCon



Start your adventure with a professional interior design tool.



Website



Visit our website to stay up to date!



Order samples



Fill in the form and order samples from our latest color scheme.



Consultation with our architect



We will draw up a projection with an office design tailored to your needs.

Metals



Op-Lite II Q desk

standard



1| Op-Lite II O desk 2| Add-on table for Op-Lite II O 3| ConScape - open set - S1



trend*

* Surcharge for metal of color group II (+10%)

O leg



Ø: 40 mm

K leg



40x40 mm

A leg

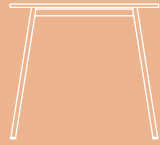

55x25 mm

F leg

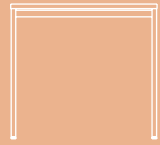

55x25 mm

Q leg

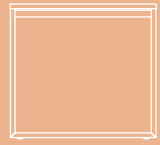

55x25 mm

O Wood leg

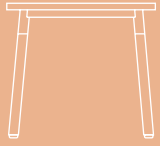

Ø: 40 mm

K Wood leg

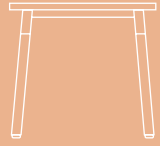

40x40 mm

T leg



50x50 mm

E leg



80x50 mm

Bench O leg



Ø: 40 mm

Bench K leg



40x40 mm

Bench A leg



55x25 mm

Bench F leg



55x25 mm

Bench Q leg



55x25 mm

Bench Wood O leg



Ø: 40 mm

Bench Wood K leg



40x40 mm



Op-Lite II O Wood desk



1| Op-Lite I O desk
2| AcuPro wall absorber

Op-Lite I

TOP

- Chipboard coated on both sides with melamine resin with increased durability - 1st class.
- Chipboard with reduced formaldehyde emission, E1 standard.
- Top finished with 2 mm thick ABS plastic edge with 3 mm radius.
- Chipboard top 25 mm thick as standard.
- Chipboard top 18 mm thick as an option - desk 7 mm lower.

FRAME

- Self-supporting steel structure comprising of 4 legs and 4 profiles screwed together. Profiles form a frame to which the top is screwed
- Legs made of Ø 40 mm or 40x40 mm profiles, other metal elements with a 40x20 mm cross-section.

Op-Lite I O

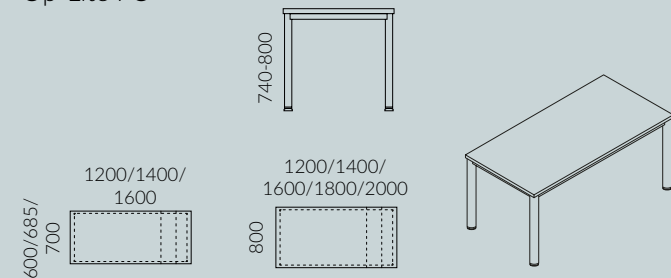

Op-Lite I K

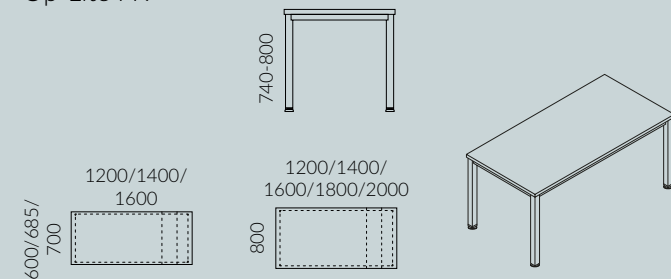

Op-Lite II

TOP

- Chipboard coated on both sides with melamine resin with increased durability - 1st class.
- Chipboard with reduced formaldehyde emission, E1 standard.
- Top finished with 2 mm thick ABS plastic edge with 3 mm radius.
- Chipboard top 25 mm thick as standard.
- Chipboard top 18 mm thick as an option - desk 7 mm lower.

FRAME

- Self-supporting steel structure comprising of welded elements of legs forming the side of the desk screwed with two undertop beams.
- Legs made of Ø 40mm profile (Op-Lite II O), 40x40mm (Op-Lite II K), 55x25mm (Op-Lite II A, F, Q), other metal parts with 40x20 mm cross section (Op-Lite II O, K, A, F, Q).
- Smooth height adjustment 740-800 mm (Op-Lite II K, O), 740-750 mm (Op-Lite II A, F, Q).

Op-Lite II O

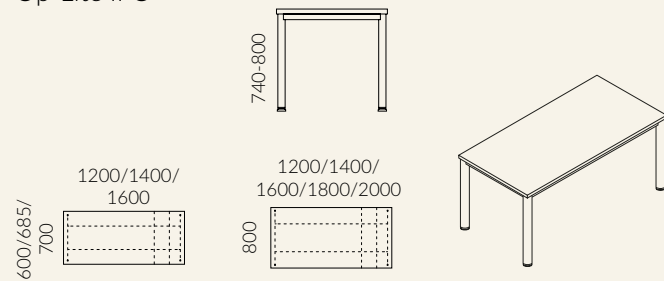

Op-Lite II K

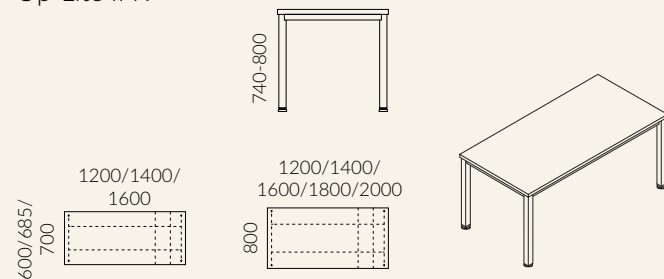

Op-Lite II K desk with board modesty panel



Op-Lite II A desk

Op-Lite II A

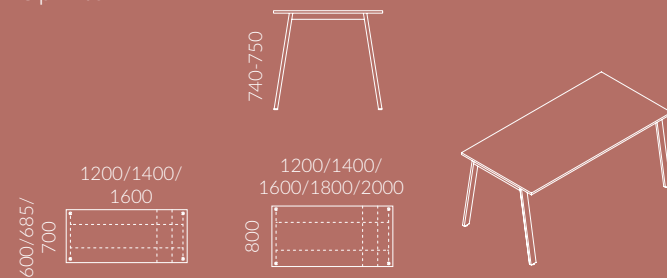

Op-Lite II F

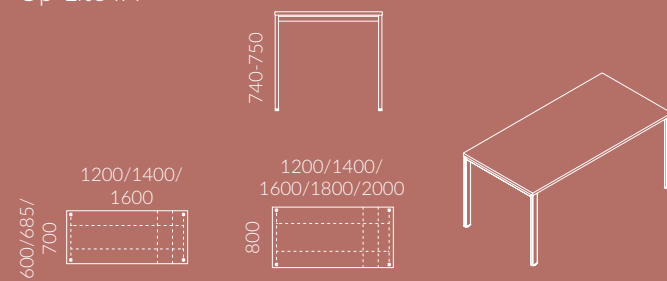

Op-Lite II Q

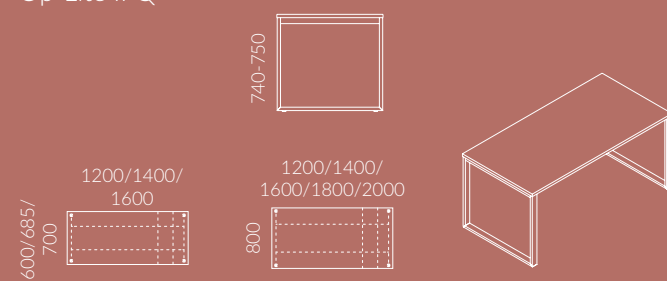

Op-Lite II O Bench 2-person workstation

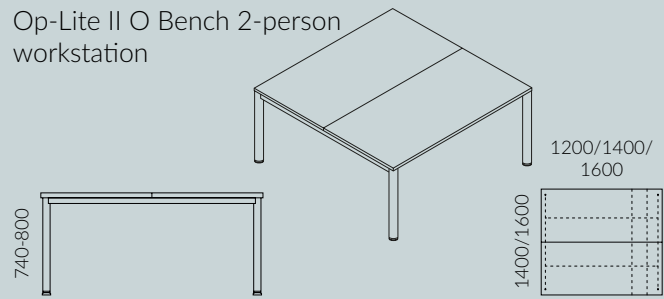

Op-Lite II K Bench 2-person workstation

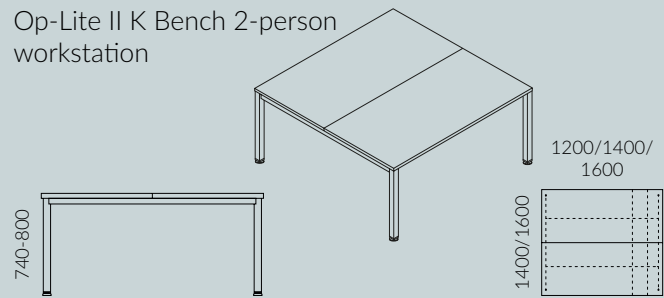

Op-Lite II A Bench 2-person workstation

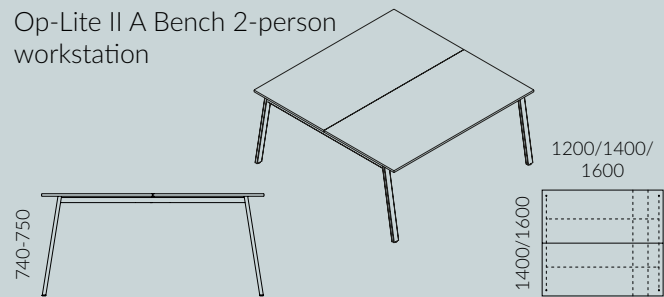

- 1] Op-Lite II K Bench 4-person workstation
- 2] AcuStix modular system of standalone partitions
- 3] Wariant mobile wall



- 1| Op-Lite II F Bench 2-person workstation with upholstered partition screen
- 2| Underdesk pedestal Op-Lite mobile 3-6 with upholstered pad
- 3| ConScape open set - S1

Op-Lite II F Bench 2-person workstation

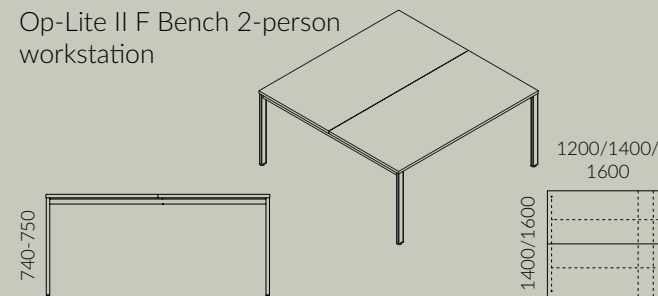

Op-Lite II Q Bench 2-person workstation

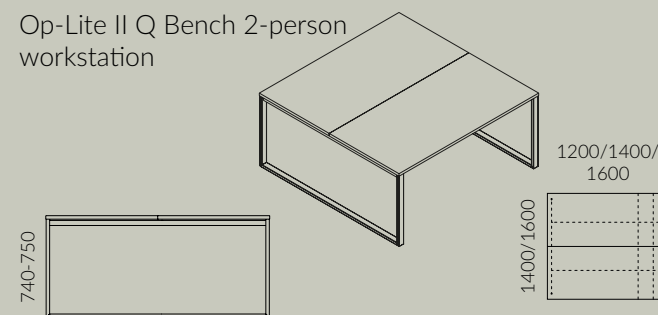

Op-Lite II O Bench 4-person workstation

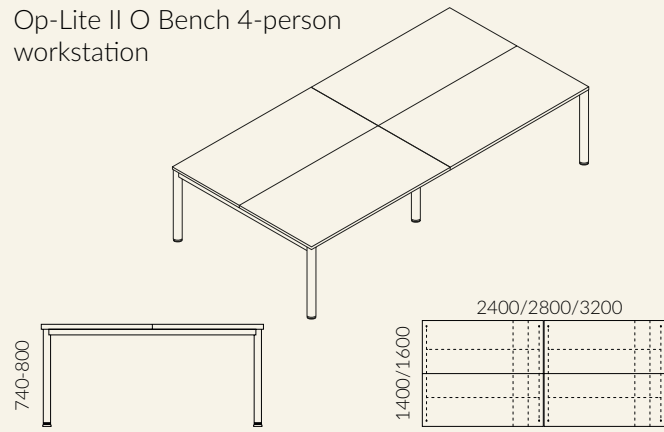

Op-Lite II F Bench 4-person workstation

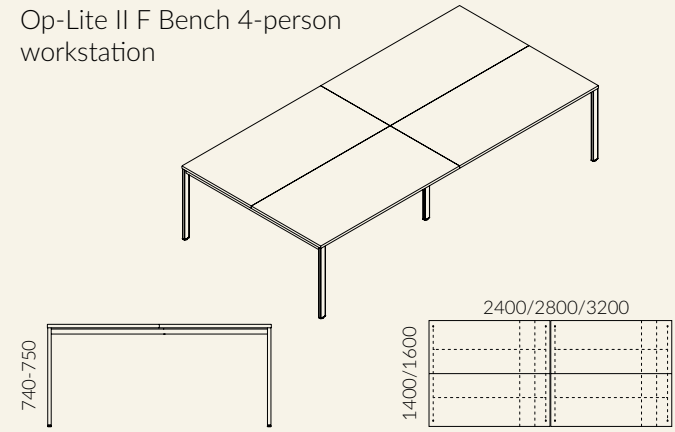

Op-Lite II K Bench 4-person workstation

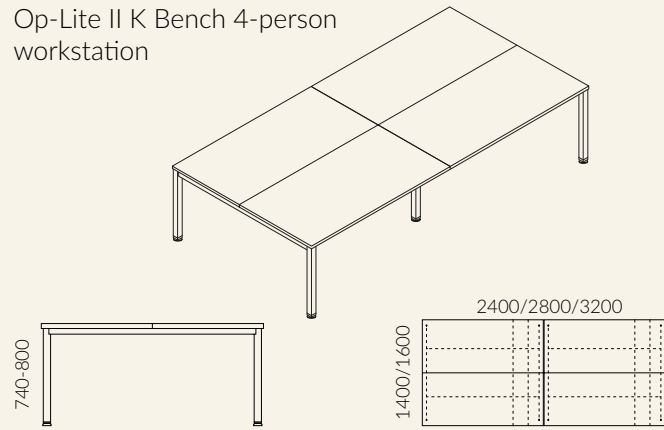

Op-Lite II Q Bench 4-person workstation

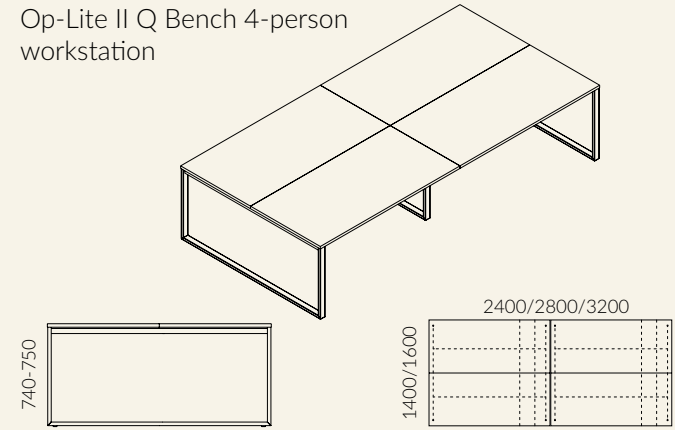

Op-Lite II A Bench 4-person workstation

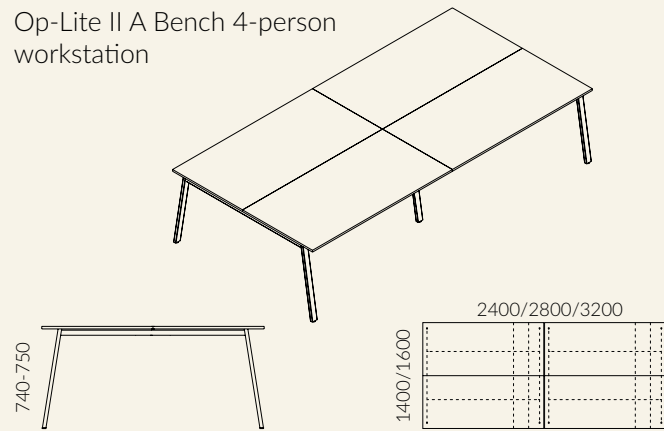

Middle element for Op-Lite II O
Bench workstation

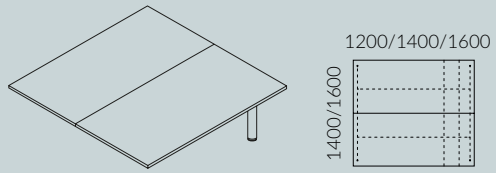

Middle element for Op-Lite II F
Bench workstation

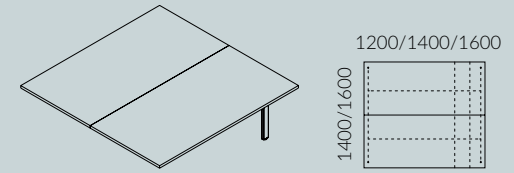

Middle element for Op-Lite II K
Bench workstation

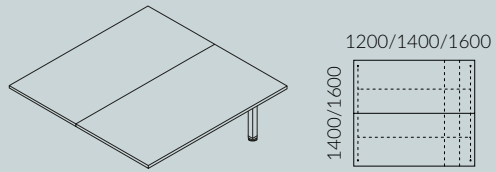

Middle element for Op-Lite II Q
Bench workstation

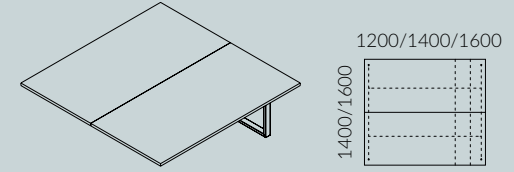

Middle element for Op-Lite II A
Bench workstation

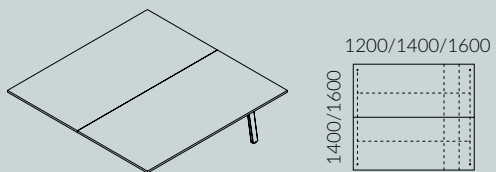



Op-Lite II Q desk with add-on table

Add-on table for Op-Lite II O

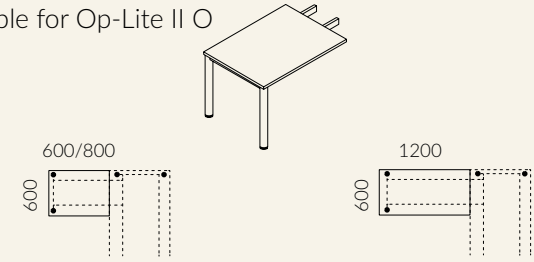

Add-on table for Op-Lite II K

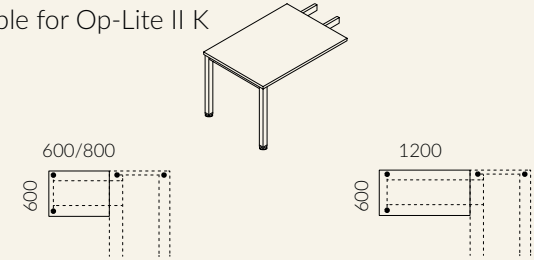

Add-on table for Op-Lite II A

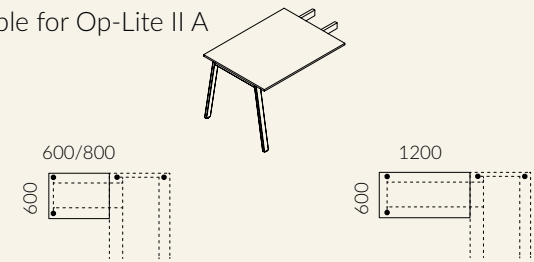

Add-on table for Op-Lite II F

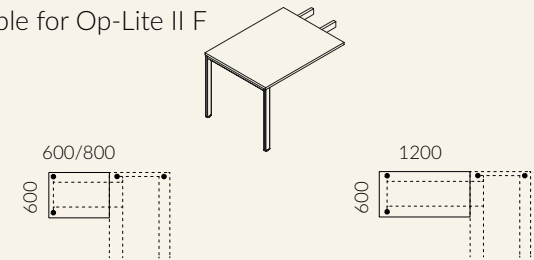

Add-on table for Op-Lite II Q

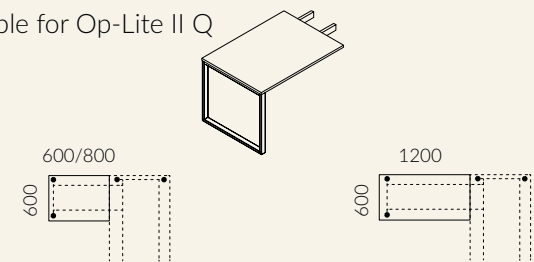

Op-Lite II Wood

TOP

- Chipboard coated on both sides with melamine resin with increased durability - 1st class.
- Chipboard with reduced for maldehyde emission, E1 standard.
- Top finished with 2 mm thick ABS plastic edge with 3 mm radius.
- Chipboard top 25 mm thick as standard.
- Chipboard top 18 mm thick as an option - desk 7 mm lower.

FRAME

- Self-supporting steel structure comprising of welded elements of legs forming the side of the desk screwed with two undertop beams.
- Angled at 9°, A-shaped legs made of beech wood with Ø40 mm or 40x40 mm cross-section and metal element with Ø40 mm or 40x40 mm profile, profile joining legs: 40x20 mm, other metal elements with 40x20 mm cross-section.

Op-Lite II Wood O

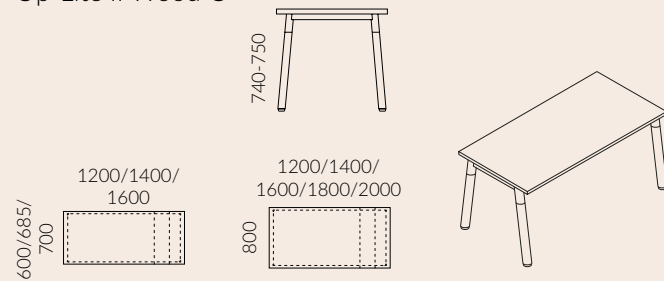

Op-Lite II Wood K

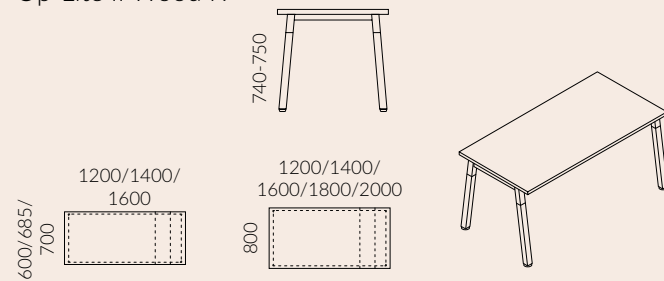

Op-Lite II Wood K desk

Op-Lite II Wood O Bench
2-person workstation

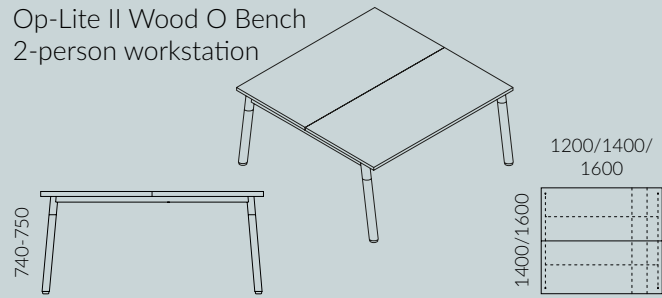

Op-Lite II Wood K Bench
2-person workstation

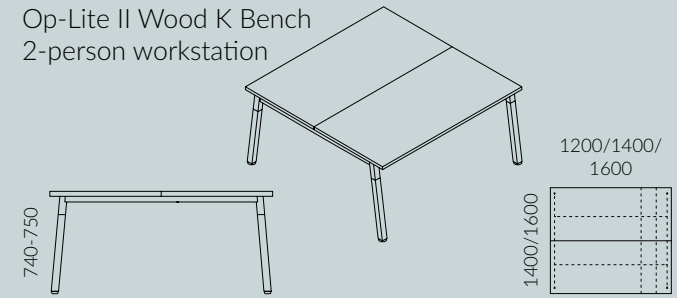

Op-Lite II Wood O Bench
4-person workstation

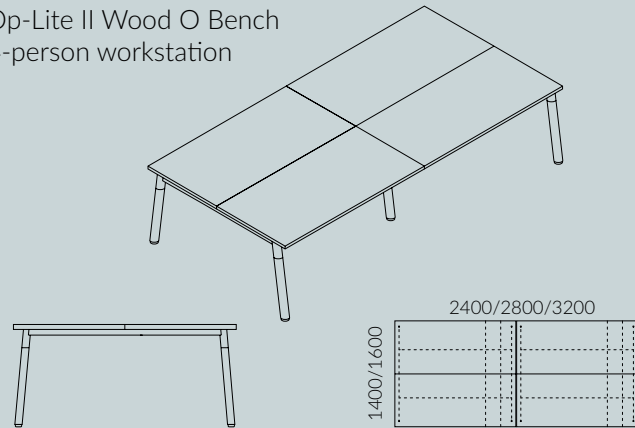

Op-Lite II Wood K Bench
4-person workstation

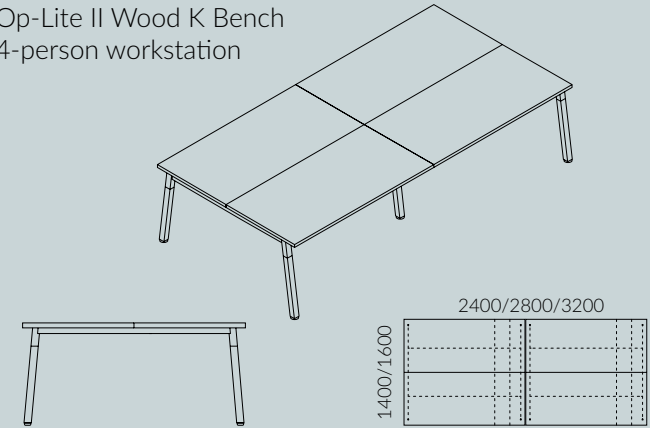

Middle element for Op-Lite II Wood O Bench workstation

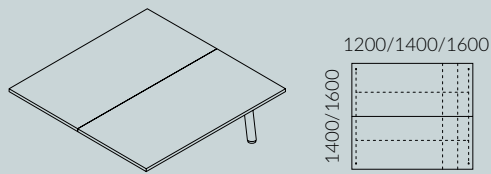

Middle element for Op-Lite II Wood K Bench workstation

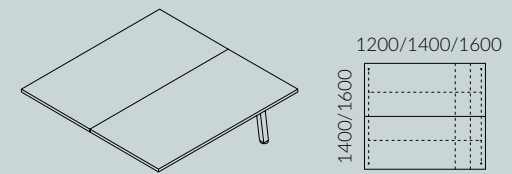

Op-Lite II Wood O add-on table

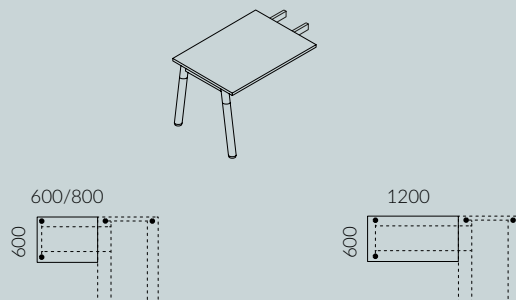

Op-Lite II Wood K add-on table

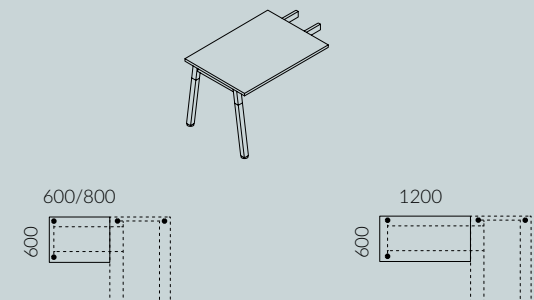



1| Op-Lite T desk with board modesty panel
2| Acoustic wall S40

Op-Lite T

TOP

- Chipboard coated on both sides with melamine resin with increased durability - 1st class.
- Chipboard with reduced formaldehyde emission, E1 standard.
- Top finished with 2 mm thick ABS plastic edge with 3 mm radius.
- Chipboard top 25 mm thick as standard.
- Chipboard top 18 mm thick as an option - desk 7 mm lower.

FRAME

- Self-supporting steel structure forming the side of the desk screwed with an undertop beam.
- Leg of the frame made of a profile with a square crosssection 50x50 mm.
- Fixed height 740 mm and leveling feet +10 mm.

Op-Lite T

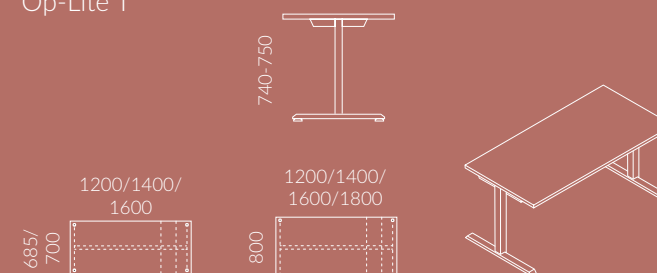

Op-Lite E

TOP

- Chipboard coated on both sides with melamine resin with increased durability - 1st class.
- Chipboard with reduced formaldehyde emission, E1 standard.
- Top finished with 2 mm thick ABS plastic edge with 3 mm radius.
- Chipboard top 25 mm thick only.

FRAME

- Frame made of two electric columns forming the side of the desk joined with undertop beams with a profile 50x25 mm.
- Three-piece electric columns with 80x50 mm cross-section.
- Plastic leveling +10 mm.

Op-Lite E

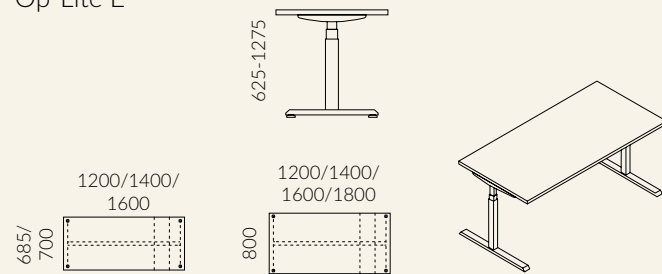

Bench connector / Bench connector with upholstered partition screen

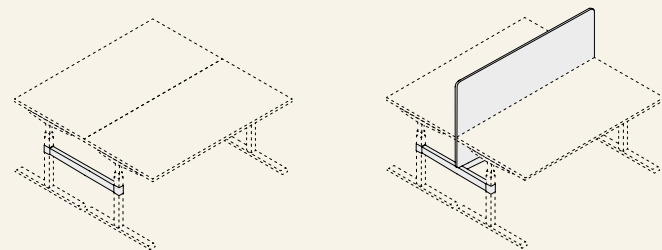

- 1| Op-Lite E desks with Bench connector with upholstered partition screen
- 2| Op-Lite 5OH filing cabinet with hinged doors and Op-Lite 5OH Op-lite Combi cabinet



composite drawers

Underdesk pedestal Op-Lite mobile 3-6

Pedestals Op-Lite

Mobile pedestal

STRUCTURE

- Chipboard coated on both sides with melamine resin with increased durability - 1st class.
- Chipboard with reduced formaldehyde emission, E1 standard.
- Carcass, top and fronts made of 18 mm thick panel board.
- Carcass finished with 0.8 mm thick ABS plastic edge and 2 mm radius.
- Top and fronts finished with 2 mm thick ABS plastic edge and 3 mm radius.
- Back wall 8 mm.

EQUIPMENT

- Plastic drawers on roll runners with B1 handles.
- Pedestal on castors 36 mm in diameter.
- Central lock with two keys.

Add-on pedestal

STRUCTURE

- Chipboard coated on both sides with melamine resin with increased durability - 1st class.
- Chipboard with reduced formaldehyde emission, E1 standard.
- Top made of 25 mm thick panel board, 18 mm as an option.
- Carcass made of 18 mm board.
- Fronts made of 18 mm thick panel board.
- Top and fronts finished with 2 mm thick ABS plastic edge and 3 mm radius.
- Carcass finished with 0.8 mm thick ABS plastic edge and 2 mm radius.
- Back wall 8 mm.

EQUIPMENT

- Plastic drawers on roll runners with B1 handles.
- Pedestal on feet H=30 mm + 10 mm.
- Central lock with two keys.

Underdesk pedestal
Op-Lite mobile 3-3-3

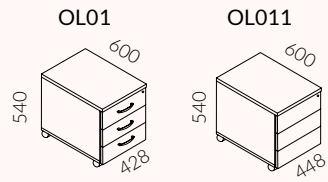

Underdesk pedestal
Op-Lite mobile 3-6

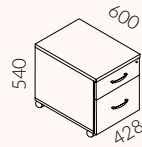

Underdesk pedestal
Op-Lite mobile 1-2-6

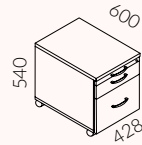

Add-on pedestal
Op-Lite 1-3-3-6

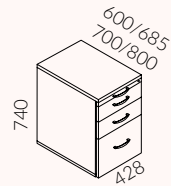

Add-on pedestal
Op-Lite 1-3-3-3-3

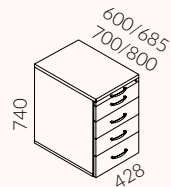

Op-Lite cabinets and shelf units

STRUCTURE

- Chipboard coated on both sides with melamine resin with increased durability - 1st class.
- Chipboard with reduced formaldehyde emission, E1 standard.
- Tops, carcasses and fronts made of 18 mm thick board.
- Tops and fronts finished with 2 mm thick ABS plastic edge and 3 mm radius.
- Carcass finished with 0.8 mm thick ABS plastic edge and 2 mm radius.
- Cabinet carcasses are factory-glued, assembled and delivered as a whole.
- Back wall is made of 3 mm thick HDF board, recessed into the groove between the sides of the cabinet. Available only in white color (impossible to change) including the inside of the cabinet.
- Possibility to change the thickness of back wall 8 mm. Only in UNI colors.
Surcharge +15% EUR.
- 18 mm thick chip board shelves with the possibility to change height every 32 mm (3 bracket holes for each level).
- 25 mm thick construction shelf (permanently mounted) in 5OH filing cabinets.
- Shelves only in the color of the carcass.
- Depth of cabinets and shelf units: 360 mm.

EQUIPMENT

- Doors equipped with 110° hinges and B1 handles, other handles available as an option.
- One point lock is mounted in cabinet doors.
- No lock in wardrobes.
- Cabinets and shelf units must be fitted to the wall. Wallmounting kit is delivered.
- All cabinets are equipped with leveling feet H=30 mm + 10 mm as standard.



- 1| Op-Lite 3OH Lite filing cabinet with hinged doors
- 2| Op-Lite 3OH shelf unit
- 3| Op-Lite 5OH Combi cabinet
- 4| Op-Lite 5OH filing cabinet with hinged doors

Op-Lite filing cabinet with hinged doors

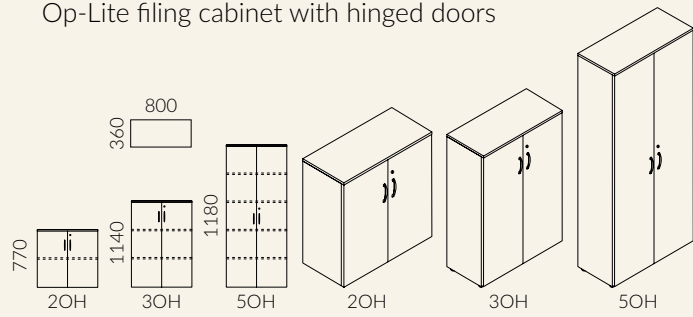

Op-Lite wardrobe with hinged doors

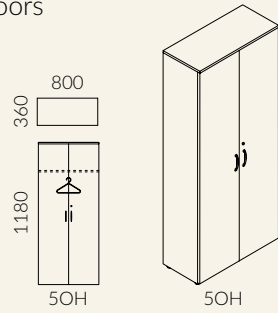

Op-Lite add-on cabinet with hinged doors

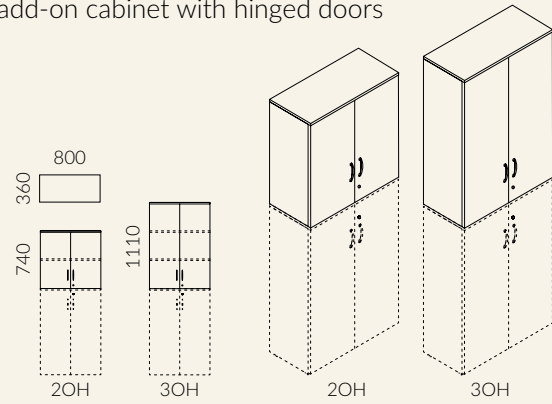

Op-lite Combi cabinet

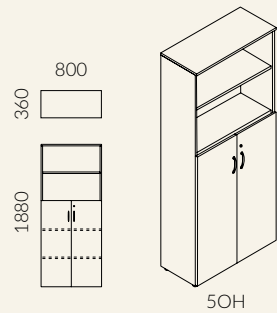

Op-Lite shelf unit

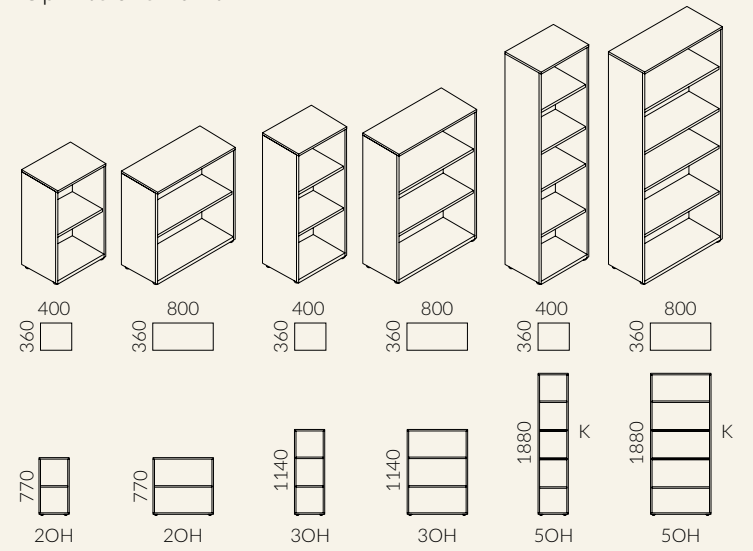

Op-Lite add-on shelf unit

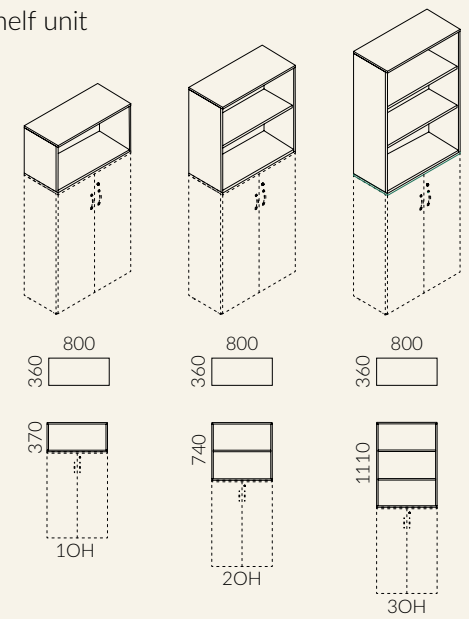

Partition screen

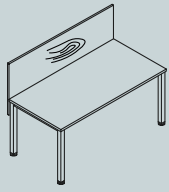

BOARD
PARTITION
SCREEN

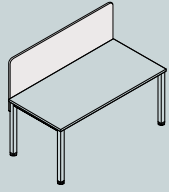

UPHOLSTERED
PARTITION
SCREEN

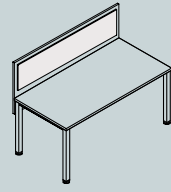

BOARD PARTITION
SCREEN WITH
UPHOLSTERED PANEL

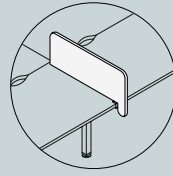

SIDE ADD-ON
PARTITION SCREEN

Modesty panels

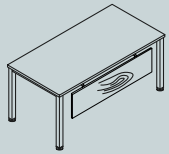

BOARD
MODESTY
PANEL

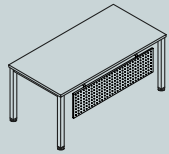

PERFORATED
MODESTY
PANEL

Horizontal cable management

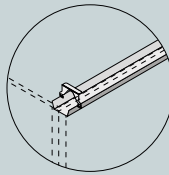

FOLD-DOWN
CABLE
CHANNEL

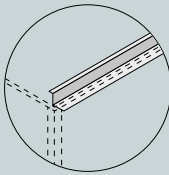

FIXED CABLE
CHANNEL

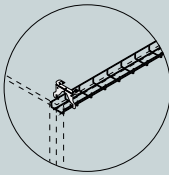

GRID CABLE
CHANNEL

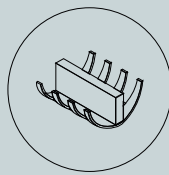

COMB CABLE
CLASP

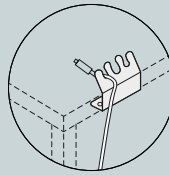

CABLE CLASP

Vertical cable management

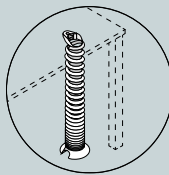

SPRING CABLE
CHANNEL

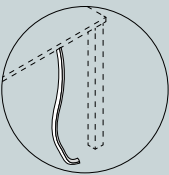

BRAIDED
SLEEVE
FOR CABLES

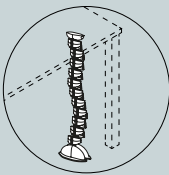

FLEXIBLE CABLE
CHANNEL

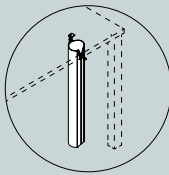

FABRIC CABLE
CHANNEL

Cable outlets

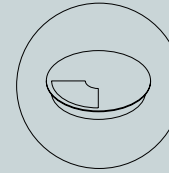

ROUND CABLE
OUTLET Ø60

Pedestals and cabinets accessories

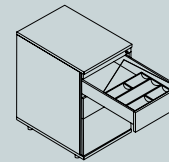

PENCIL INSERT

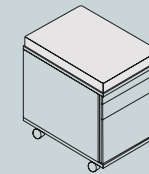

UPHOLSTERED
PAD



ANGLE IRON

Complementary accessories

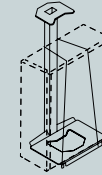

PC HOLDER

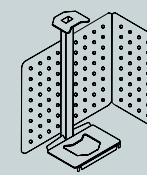

PC HOLDER WITH
PERFORATED PANEL

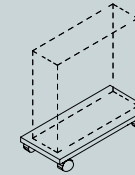

PC TROLLEY WITH
CASTORS

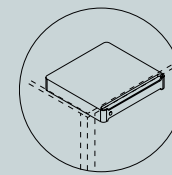

UNDERDESK
DRAWER

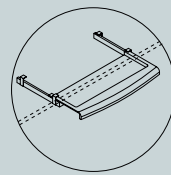

KEYBOARD
DRAWER



 MARO Office Furniture

 @maroofficefurniture

 MARO Office Furniture

 MARO Office Furniture

Fabryka Mebli Biurowych MARO sp. z o. o.
PL 62-052 Komorniki, ul. Fabianowska 100
NIP PL5992575691

 +48 61 890 00 00

 maro@maro.eu

maro.eu